

Addressing & Address Mapping

By Nidhi Jindal

Nidhi.jindal@ggnindia.dronacharya.info

Introduction

Four levels of addresses are used in an internet employing the TCP/IP protocols: physical (link) addresses, logical (IP) addresses, port addresses, and specific addresses

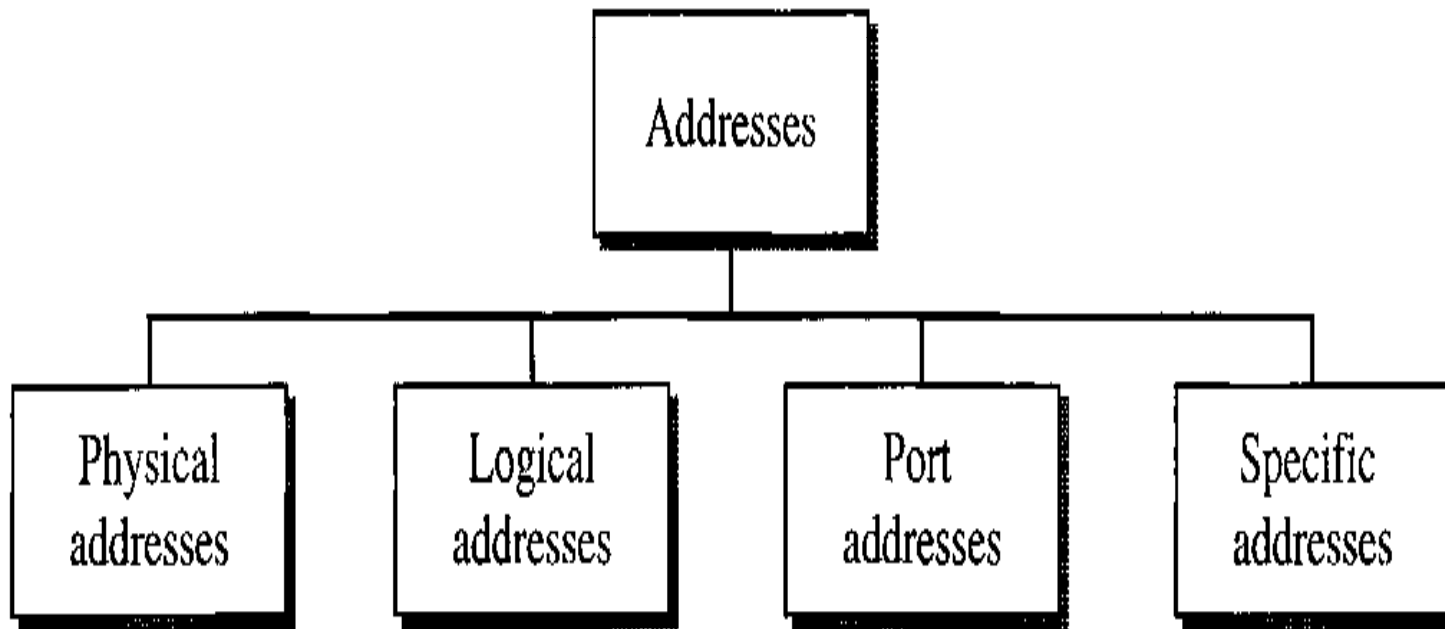

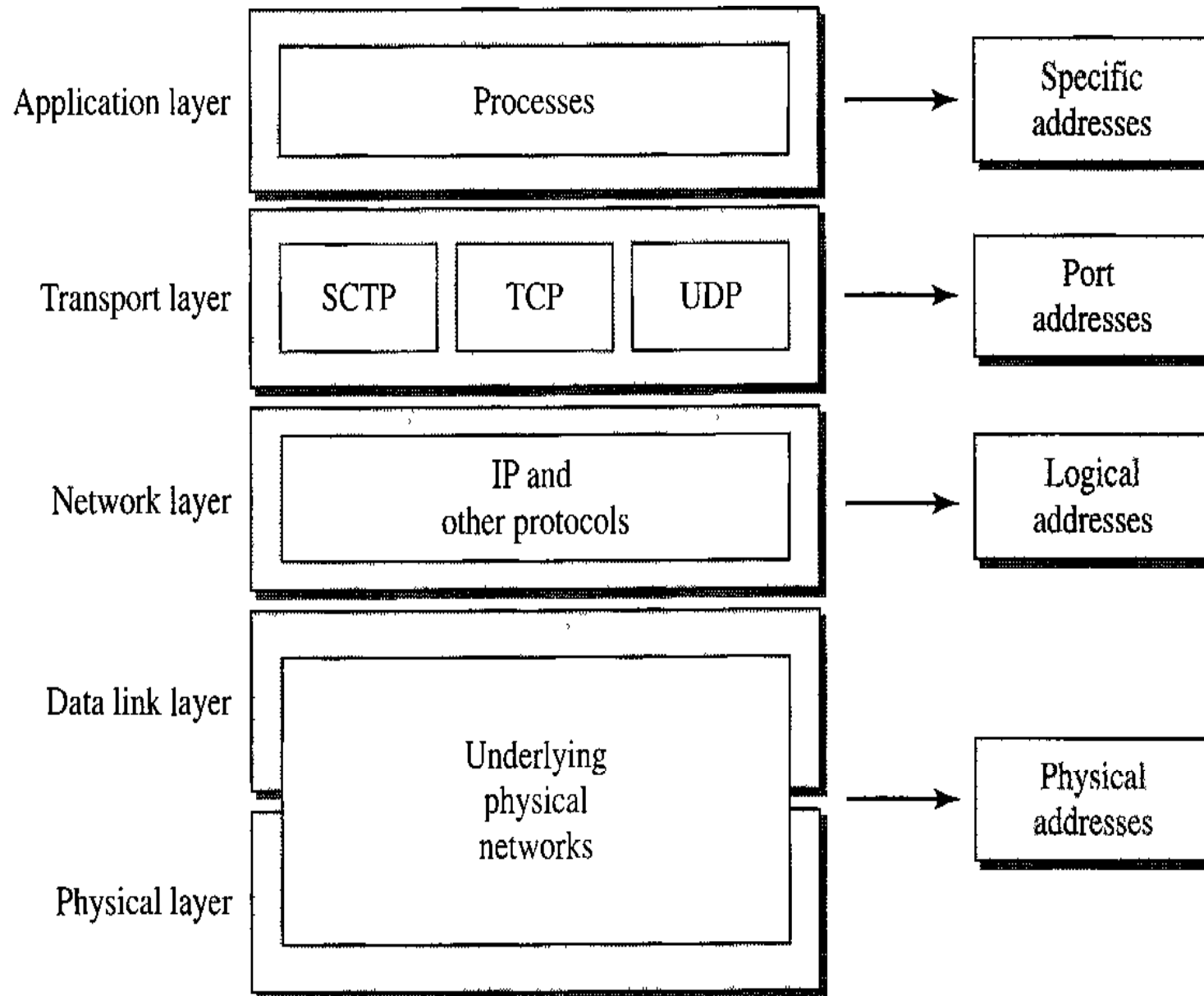

Physical Addresses

The physical address, also known as the link address, is the address of a node as defined by its LAN or WAN. It is included in the frame used by the data link layer. It is the lowest-level address. The size and format of these addresses vary depending on the network. For example, Ethernet uses a 6-byte (48-bit) physical address that is imprinted on the network interface card (NIC).

07:01:02:01:2C:4B

A 6-byte (12 hexadecimal digits) physical address

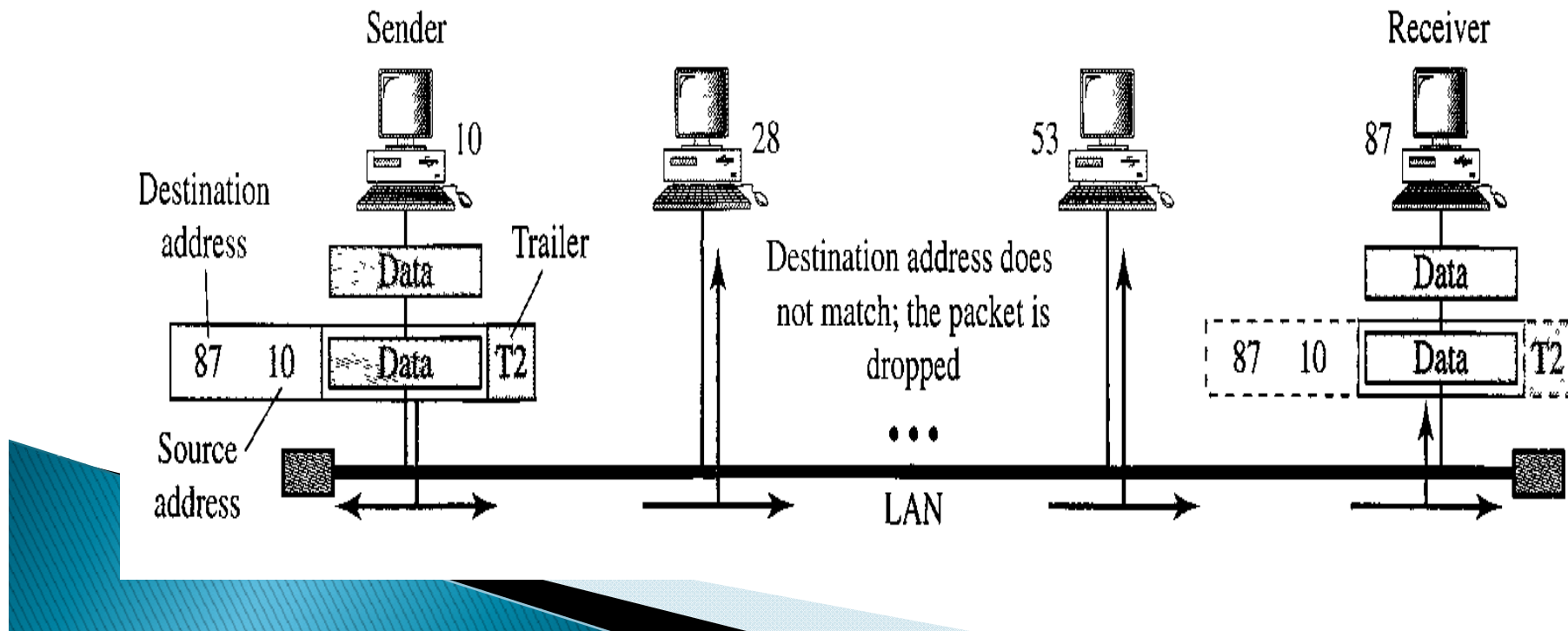

Logical Addresses

Logical addresses are necessary for universal communications that are independent of underlying physical networks. Physical addresses are not adequate in an internetwork environment where different networks can have different address formats. A universal addressing system is needed in which each host can be identified uniquely, regardless of the underlying physical network. The logical addresses are designed for this purpose. A logical address in the Internet is currently a 32-bit address that can uniquely define a host connected to the Internet. No two publicly addressed and visible hosts on the Internet can have the same IP address.

**The physical addresses will change from hop to hop,
but the logical addresses usually remain the same.**

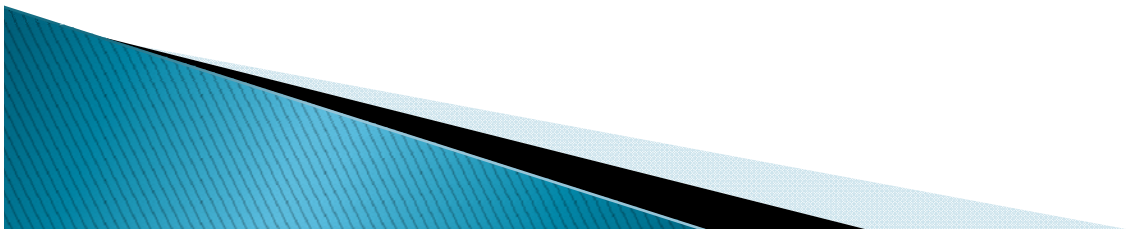

The network layer, however, needs to find the physical address of the next hop before the packet can be delivered. The network layer consults its routing table and finds the logical address of the next hop (router 1) . The ARP finds the physical address of router 1 that corresponds to the logical address of destination. Now the network layer passes this address to the data link layer, which in turn, encapsulates the packet with physical destination address and physical source address

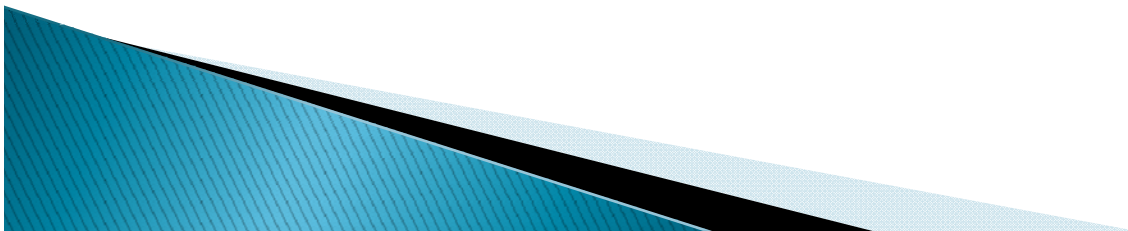

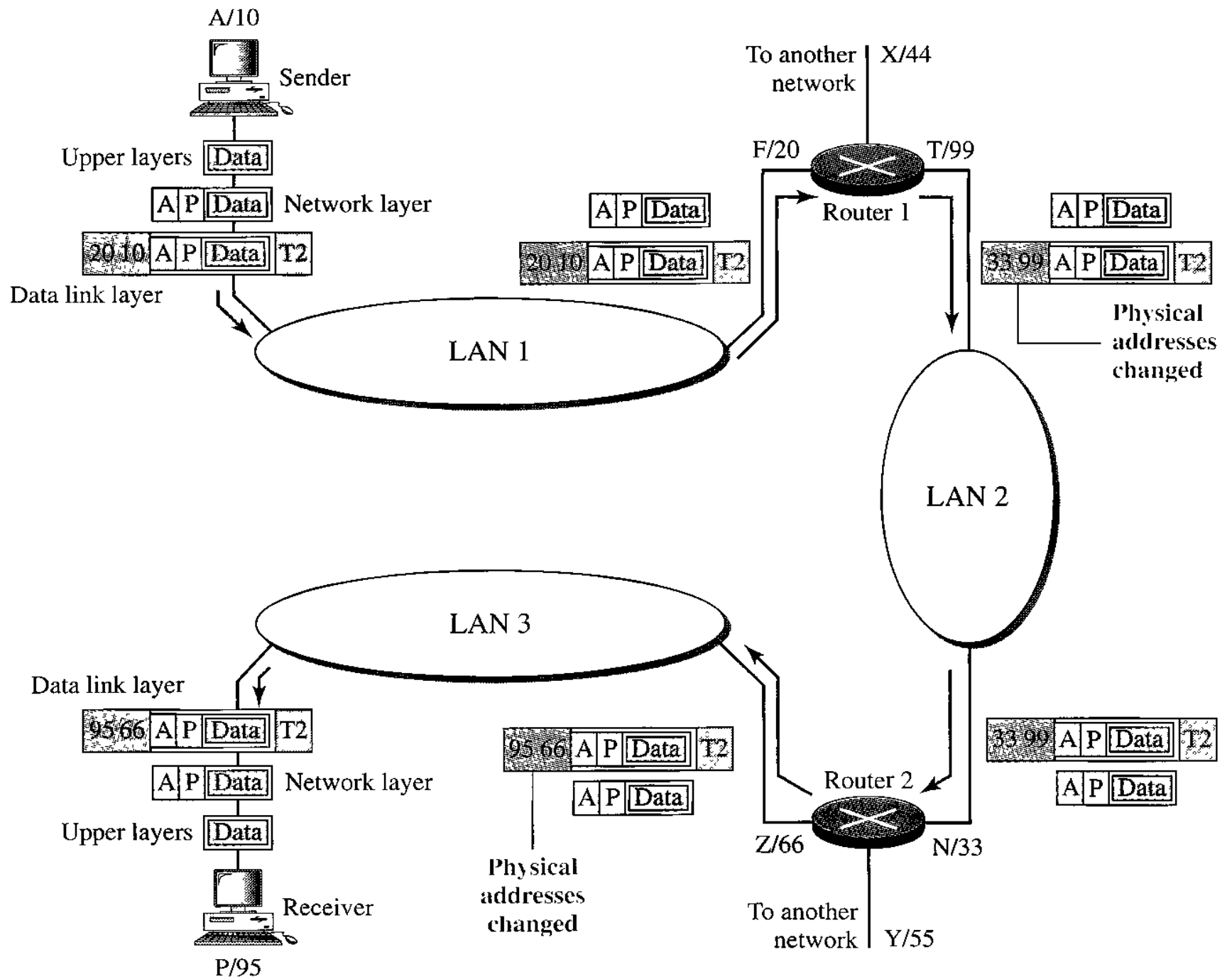

Port Addresses

The IP address and the physical address are necessary for a quantity of data to travel from a source to the destination host. Today, computers are devices that can run multiple processes at the same time. The end objective of Internet communication is a process communicating with another process. For example, computer A can communicate with computer C by using TELNET. At the same time, computer A communicates with computer B by using the File Transfer Protocol (FTP). For these processes to receive data simultaneously, we need a method to label the different processes. In other words, they need addresses. In the TCP/IP architecture, the label assigned to a process is called a port address. A port address in TCP/IP is 16 bits in length.

**The physical addresses change from hop to hop,
but the logical and port addresses usually
remain the same.**

753

A 16 bit port address represented as one single number



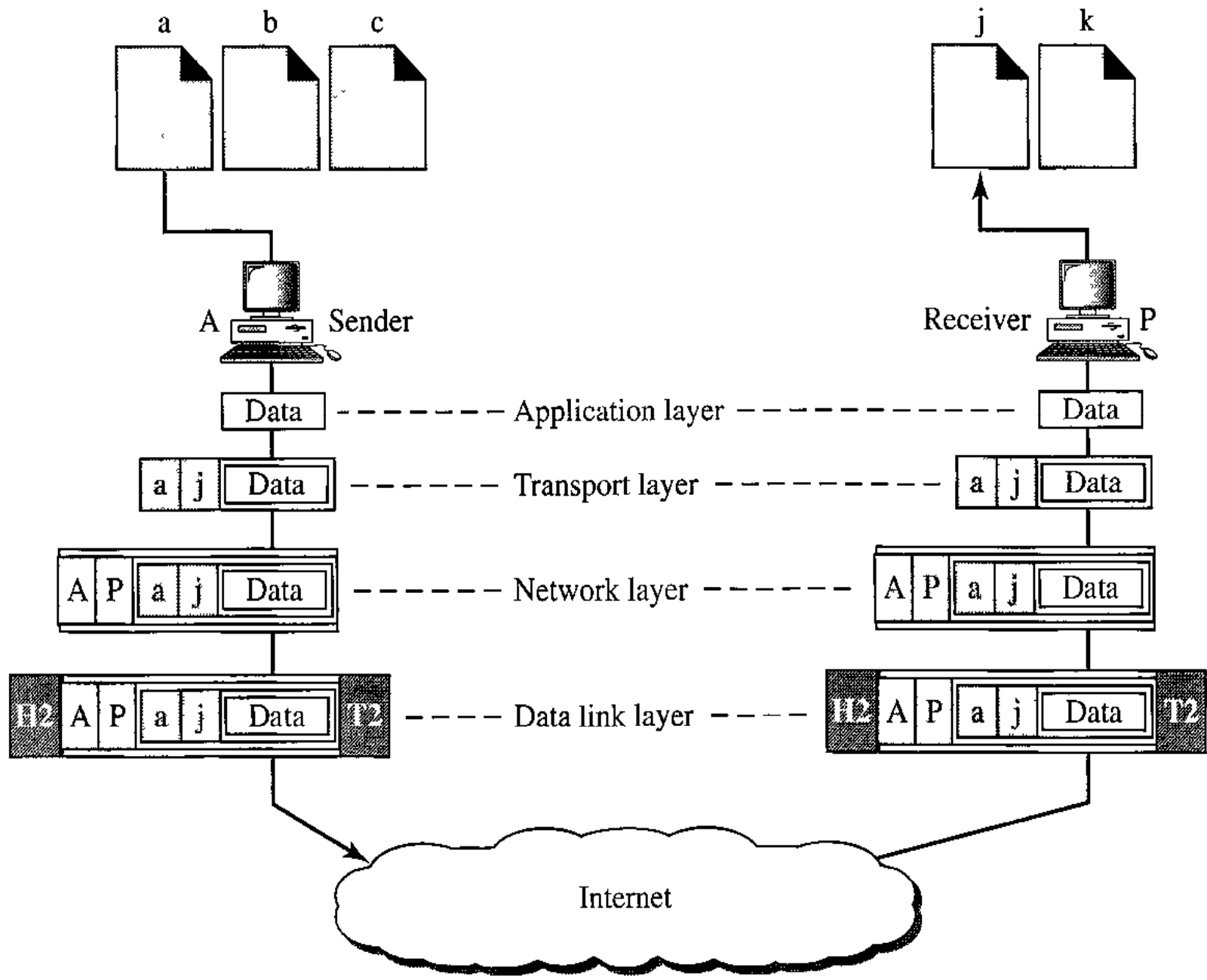

Specific Addresses

Some applications have user-friendly addresses that are designed for that specific address . Examples include the e-mail address (for example, frozen @fhda.edu) and the Universal Resource Locator (URL) (for example, www. mhhe.com). The first defines the recipient of an e-mail; the second is used to find a document on the World Wide Web. These addresses, however, get changed to the corresponding port and logical addresses by the sending computer.

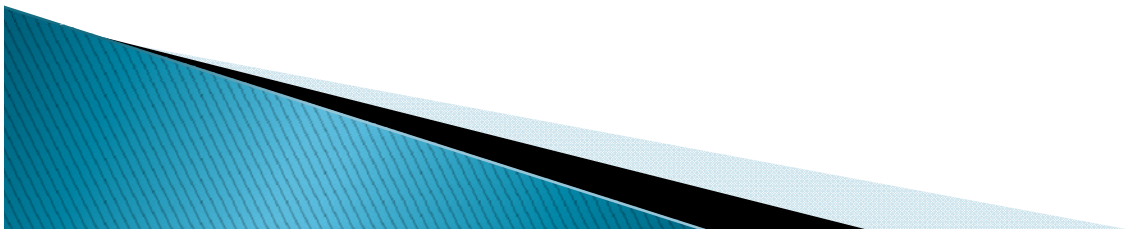

ADDRESS MAPPING

An internet is made of a combination of physical networks connected by internetworking devices such as routers. A packet starting from a source host may pass through several different physical networks before finally reaching the destination host. The hosts and routers are recognized at the network level by their logical (IP) addresses. However, packets pass through physical networks to reach these hosts and routers . At the physical level, the hosts and routers are recognized by their physical addresses.

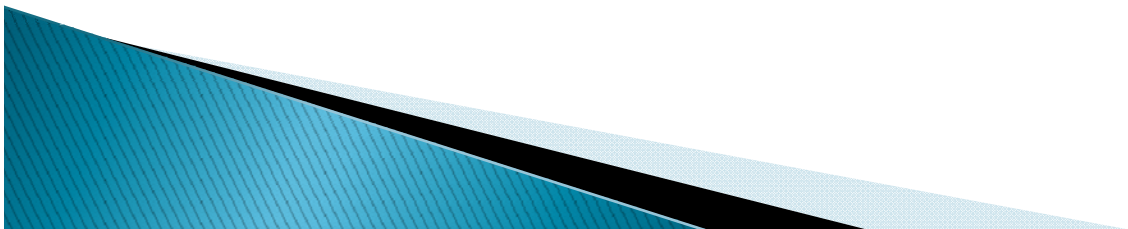

Applications

- ▶ Addressing and address mapping is used in each application layer protocol which is based on connection oriented service. For Example:

- FTP
- SMTP
- MIME
- HTTP

In each case address mapping needs to be done to find the desired destination

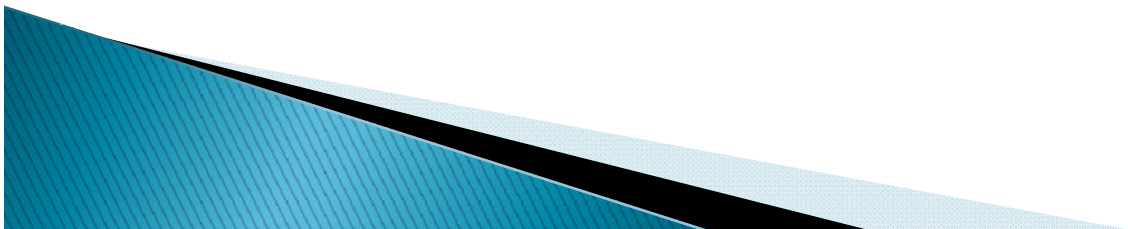

Scope of Research

- ▶ Address mapping in IPv6

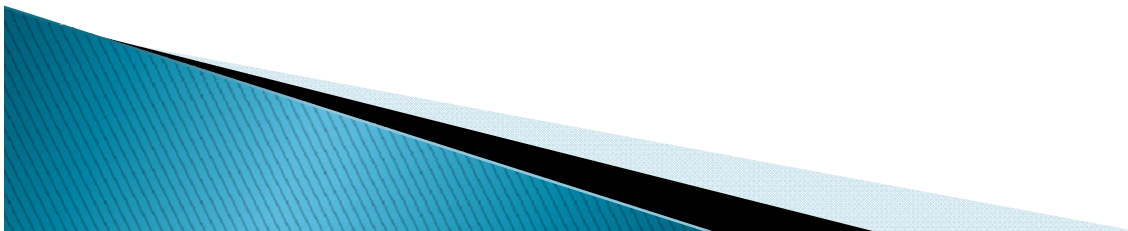

Assignment 7

- ▶ What is the difference between transport layer level addresses and network layer level addresses? Explain with the help of suitable example.

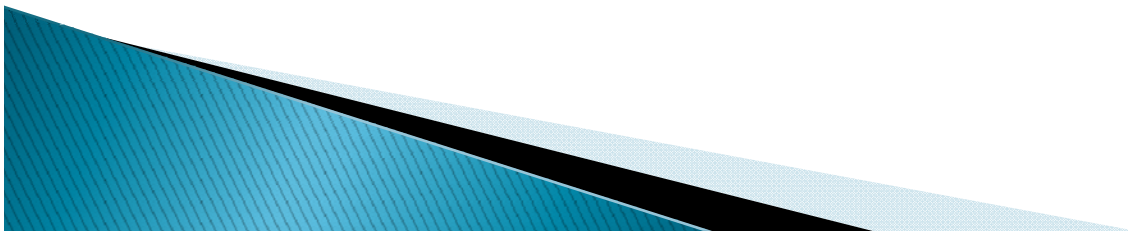

THANKYOU

